

REVISIONS			
REV.	DESCRIPTION	DATE	APPROVED
-	NEW RELEASE	-	-
1	MOUNTING BRACKET WAS FABRICATED NOW PURCHASED. REPLACED COMPRESSION PLATE WITH 2 PLATE WASHERS.	4/23/2026	F. BRYANT

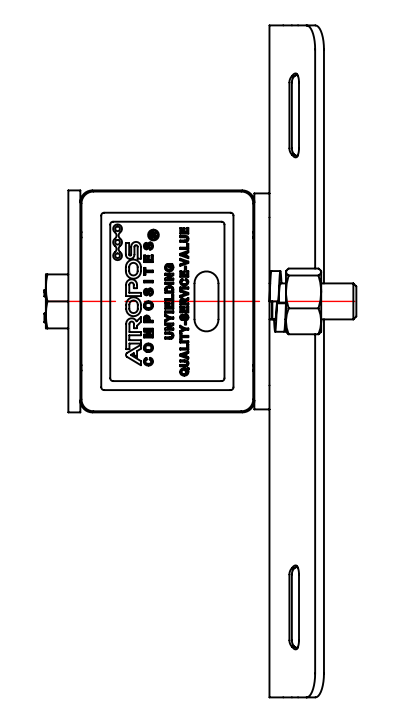

ITEM NO.	PART NUMBER	DESCRIPTION	QTY.
1	A700-0042	CROSSARM MOUNTING BRACKET, TANGENT, 3400 SERIES	1
2	3402A096-T011-X902 CA	ASSEMBLY, RUS, 3402 CROSSARM, TANGENT, 8' TYPE 4 DRILL PATTERN	1
3	A616-0042-01	LOCK WASHER, FOR 3/4" SCREW, 0.766" ID, 1.265" OD, 0.188" THICK, HOT-DIPPED GALVANIZED STEEL	2
4	A616-0019-02	EXTREME STRENGTH NUT, HEX, 3/4"-10, 2H, HOT-DIPPED GALVANIZED	2
5	A616-0020-02	BOLT, HEX, 3/4"-10 X 6.00" LONG, HOT DIPPED GALVANIZED STEEL, 1-1/8" DRIVE	2
6	A700-0047	WASHER, SQUARE, 4.625" X 4.625" X 0.25 THICK WITH 0.81 THRU HOLE	2

GENERAL NOTES		UNLESS OTHERWISE SPECIFIED		NAME	DATE
DIMENSIONS ARE IN INCHES		DRAWN: F. BRYANT		F. BRYANT	10/13/2025
STANDARD TOLERANCES		CHECKED: TJS		TJS	10/21/2025
FRACTIONAL: ±1/32		ANGULAR:		ENG APPR:	
MACHINED: +0.5' BEND: ±2'		TWO PLACE DECIMAL: ±0.03		MFG APPR:	
THREE PLACE DECIMAL: ±0.005		INTERPRET GEOMETRIC TOLERANCING PER: ANSI Y14.5		Q.A.:	
MATERIAL		PROPRIETARY AND CONFIDENTIAL			
FINISH		THE INFORMATION CONTAINED IN THIS DRAWING IS THE SOLE PROPERTY OF VETURIO. ANY REPRODUCTION IN PART OR AS A WHOLE WITHOUT THE WRITTEN PERMISSION OF VETURIO IS PROHIBITED.			
DO NOT SCALE DRAWING		SIZE DWG. NO.		REV	
		D 3402A096-T011-X902		1	
		SCALE: 1:8		WEIGHT: 55.94	
				SHEET 1 OF 1	

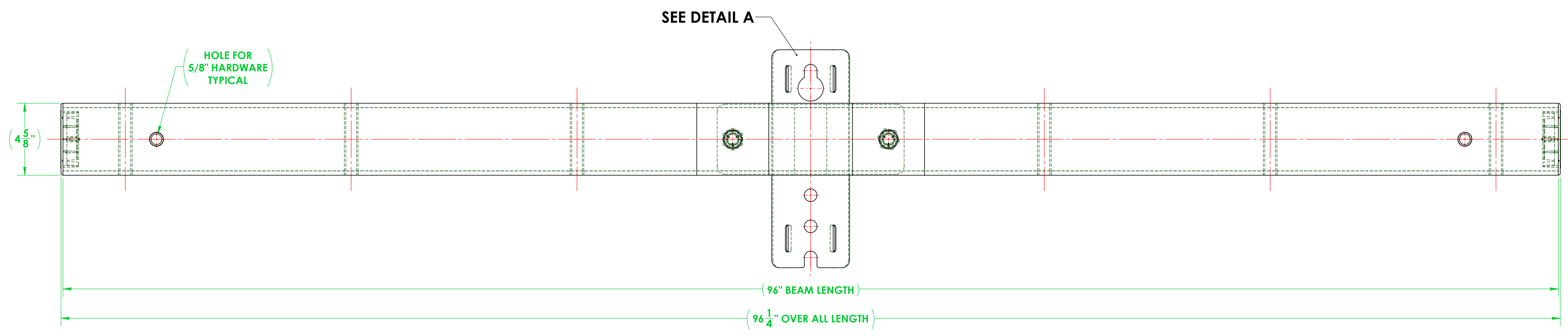
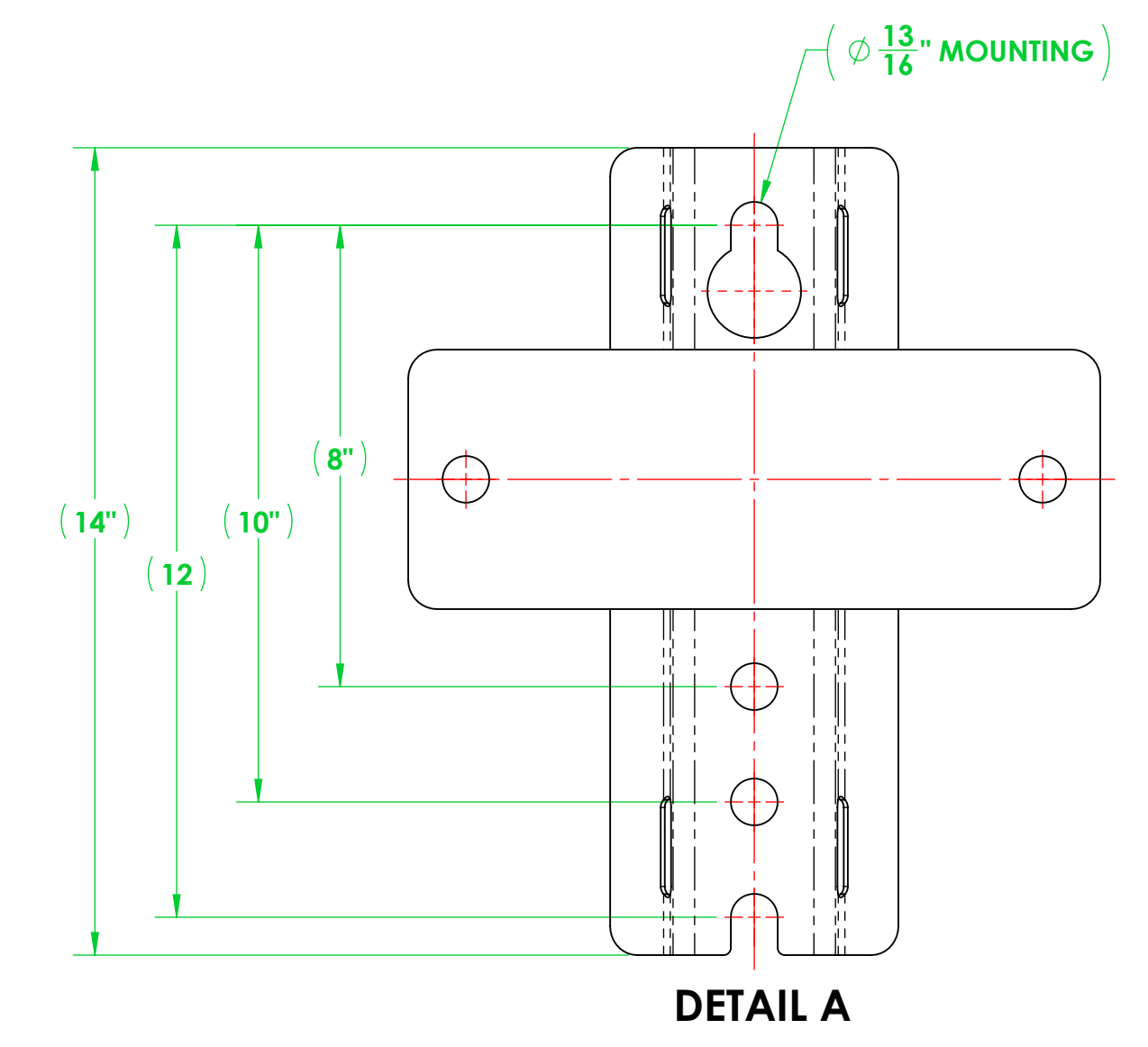
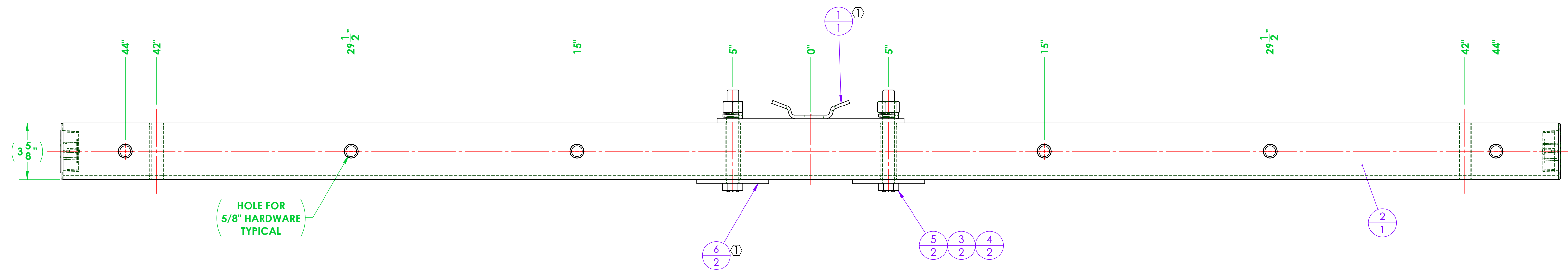

TITLE: ASSEMBLY, TANGENT, 3402, (6) WIRE, 8 FT.